



Soil, Waste & Vent Piping System





PROFILE

In 1971, PALING Industries was established to produce uPVC pipes and fittings in Malaysia and through the years has expanded its wide range of products from pipes and fittings to sanitary products like plastic cisterns and other accessories for various applications in water and building industries.

In 2001, PALING entered into a global partnership with the Etex Plastics Group, now known as Aliaxis, a world leader in plastic piping systems. With a reputation equally based on the same high principles of customer service, product excellence and technical innovation, a substantial investment program has taken place to support these common aims.

Stringent factory quality control, key to our success

Strict internal control over our products enables PALING to meet the relevant Malaysian, British, Australian, American and Japanese high standards and to be certified by SIRIM (Standard and Industrial Research Institute of Malaysia). Such certifications enable us to obtain local authorities approvals for use in the public and private projects and such rigor, help us build a reputation of excellence amongst the most demanding international contractors, for products meeting daily the highest demanding architectural and structural requirements.

It is not surprising then that the task of supplying the required pipes and fittings to mega projects such as KLCC (one of the tallest building in the world), KLIA (Kuala Lumpur International Airport) and Putrajaya (the new Administrative Center of the Federal Government of Malaysia) was best awarded to the specialist who has the resources, expertise and experience to meet the intricate and challenging specification requirement.

Wide range of innovative products, key to your success

The unmistakable reliable quality and adaptability has resulted in PALING products being widely used from classic to high-tech infrastructure projects such as water supply, construction of buildings and telecommunication, qualifying PALING in playing the significant role in national development.

PALING's product ranges from uPVC pressure pipes and fittings, soil, waste and vent (SWV) system, underground sewer system, rainwater piping system to telecom and electrical conduits. Accurate control of dimensions & performance, excellent hydraulic flow characteristics, economical and simple to install features are among the benefits of using PALING products.

It's no wonder the versatile and comprehensive ranges of PALING products receive recognition among authorities and contractors who are discerning in their choice of piping system.



OUR SERVICES

Paling Industries has for more than 30 years been directly involved in the manufacture and supply of uPVC pipes and fittings for pressure and non-pressure applications as well as plastic sanitary products in the building and construction industries.

Technical and Commercial Assistance for every technical advice on building site

To date, thousands of kilometers of PALING piping are in service in water mains, soil, waste and vent (SWV) system, underground sewage scheme, as well as fibre optic cable network. In line with the company's commitment to product quality, PALING Industries has been continuously engaged in enhancing its material formulation, processing equipment and tools, and testing facilities in order to improve the performance and reliability of its products.

Our technical and sales teams assure an active presence at site and dedicate their time to acquaint clients with our product range. Our technical department answers every special demand and proposes solutions to clients' requirement.

For a quick supply to your building site delivery within 72 hours

PALING supplies more than 1200 items through an extensive network of specialized distributors equipped with modern and efficient logistic, ensuring delivery, throughout major towns in peninsular Malaysia within 72 hours.*

** Subject to Terms and Conditions.*

CUSTOM-MADE PRODUCT SERVICES

For all your specific needs on parts and fittings, we provide custom-made products to meet your specification.

To meet your specification, our team of engineers studies your special request in order to produce according to your specific needs.



TRAINING CENTER

In this competitive age where customer's satisfaction prevails, we believe in working hand in hand with our fellow installers to ensure continuous product reliability and excellent workmanship to secure a niche in the market. In Paling, despite offering our customers premium quality products, we are also here to share our years of experience in this industry. Well equipped with technical expertise that has mature jobsite experience, our training centre offers programs that impart invaluable knowledge and introduces practical skills of good work practices to optimize the quality of any installation. In addition, we share insights of standards and regulations to keep our partners in the industry abreast of the latest development.

Our Concept

- To provide comprehensive knowledge
- To upgrade skills
- To improve qualifications and competencies

Our Target

PALING is to ensure that the applicant demonstrates his or her ability to properly prepare and assemble plastic plumbing materials used in plumbing systems.

Subjects

- Plumbing
- Sewerages
- Water Reticulation
- Sanitary



The quality of the solvent cemented joint determines the effectiveness of the plastic pipe system as a whole. For this reason, we offer data sheets, booklets, an installation video, installation training and certification seminars as complete educational packages to those who take good joining techniques as seriously as we do.

PLEASE CONTACT OUR SALES TEAM

Tel : 603 - 6189 8333 (General)
603 - 6189 6389 (Sales)
Fax : 603 - 6188 3810
Email : Domestic
sales@paling.com.my
Export
export@paling.com.my



OFFICIAL CERTIFICATION

For years, PALING'S range of uPVC Pipes and Fittings has its quality controlled, approved and certified by SIRIM and NSF



Standard and Qualification

SWV Pipes

- ❖ Dimensions and performance meet the requirement of standards.
- ❖ High quality of finish with smooth internal and external surface.
- ❖ Provides low coefficient of flow friction.
- ❖ Excellent resistance to chemicals found in domestic effluent.
- ❖ Remain stable under elevated temperature.
- ❖ Formulated to withstand weathering effect.

Pipe Marking

- 1: The word "PALING" or Paling Logo with the word "PALING"
- 2: The word SIRIM CERTIFIED or MS Logo
- 3: SIRIM License number
- 4: Standard conformance and year of standard
- 5: Nominal size
- 6: Manufacturing date
- 7: Manufacturing Shift code
- 8: Lead Free

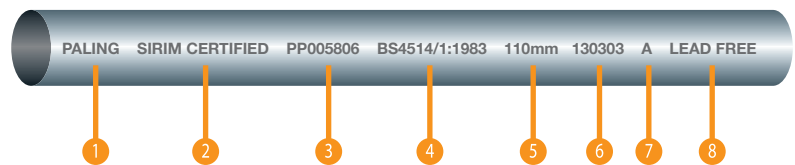

SWV Fittings

- ❖ Wall thickness of fittings and materials are formulated to achieve strength that exceeds the performance of standards.
- ❖ High quality of finish with smooth internal and external surface.
- ❖ Provides low coefficient of flow friction.
- ❖ Excellent resistance to chemicals found in domestic effluent.
- ❖ Remain stable under elevated temperature.
- ❖ Formulated to withstand weathering effect.
- ❖ Comprehensive range of fittings offers multiple solutions.



PALING products are accurately designed and formulated to consistently and continuously exceed the performance aspects of standards.

With SIRIM and ISO 9001:2000 certifications, they undoubtedly provide an independent assurance to users or customers that Paling products are manufactured under an effective system of inspection, testing, supervision and control.

- Paling • The word "Paling" or Paling Logo
- 110 mm • Nominal Size
- BS 4514 • Standard Conformance

Official Certification

For years, PALING's range of uPVC Soil, Waste & Vent Pipes & Fittings has its quality controlled, approved and certified by **SIRIM**



PIPES

MODEL	NOM. SIZE (mm)	SPECIFICATION
Waste	32, 40 & 50	MS 978:1985
Soil & Vent	82, 110 & 160	BS 4514:1983

FITTINGS

MODEL	NOM.	SPECIFICATION SIZE (mm)
Bend (Swept)	32, 40, 50, 82, 110 & 160	MS 978:1985 / BS 4514:1983
Bend W/I/O (Swept)	40, 50, 82, 110 & 160	MS 978:1985 / BS 4514:1983
45° Bend (Unswept)	32, 40, 50, 82, 110 & 160	MS 978:1985 / BS 4514:1983
45° Bend W/I/O (Unswept)	50, 82, 110 & 160	MS 978:1985 / BS 4514:1983
45° Equal Single Branch (Unswept)	50, 82 & 110	MS 978:1985 / BS 4514:1983
45° Equal Single Branch W/I/O (Unswept)	82 & 110	BS 4514:1983
45° Unequal Single Branch (Unswept)	160 x 110	BS 4514:1983
45° Unequal Single Branch W/I/O (Unswept)	160 x 110	BS 4514:1983
45° Unequal Double Branch W/I/O (Unswept)	160 x 110	BS 4514:1983
45° Unequal Double Branch (Unswept)	160 x 110	BS 4514:1983
Boss Connector	82 x (32, 40, 50), 110 x (32, 40, 50, 82) & 160 x 82	BS 4514:1983
Bush Socket Reducer	40 x 32, 50 x 32, 50 x 40, 82 x 50, 110 x 82, 110 x 50 & 160 x 110	MS 978:1985 / BS 4514:1983
Concentric Reducer	82 x 50, 110 x 50 & 160 x 110	BS 4514:1983
Equal Double Branch (Swept)	50 & 110	MS 978:1985 / BS 4514:1983
Equal Double Branch W/I/O (Swept)	50 & 110	MS 978:1985 / BS 4514:1983
Equal Single Branch (Swept)	32, 40, 50, 82, 110 & 160	MS 978:1985 / BS 4514:1983
Equal Single Branch W/I/O (Swept)	40, 50, 82, 110 & 160	MS 978:1985 / BS 4514:1983
Expansion Coupler	82, 110 & 160	BS 4514:1983
Expansion Coupler Set	110	BS 4514:1983
Floor Gully with Trap & I/O	110 x 82 & 110 x 50	BS 4514:1983
Floor Gully with Trap	110 (85) x 40 & 110 (105) x 40	BS 4514:1983
Inspection Opening & Frame	82 x 50, 110 x 82, 110 x 50 & 160 x 82	BS 4514:1983
Level Invert Reducer	50 x 32, 82 x 50, 110 x 82 & 110 x 50	MS 978:1985 / BS 4514:1983
'P' Trap	50, 82, 110	MS 978:1985 / BS 4514:1983
'P' Trap with Vent	50 x 32, 110 x 50	MS 978:1985 / BS 4514:1983
'S' Trap	110	BS 4514:1983
Straight Coupler	32, 40, 50, 82, 110 & 160	MS 978:1985 / BS 4514:1983
Socket Plug with Screw On Cap	32, 40, 50, 82, 110 x 82	MS 978:1985 / BS 4514:1983
Unequal Single Branch W/I/O (Swept)	160 x 110	BS 4514:1983
Unequal Single Branch (Swept)	110 x 82 & 160 x 110	BS 4514:1983
Unequal Four Way Branch (Unswept)	110 x 50	BS 4514:1983
Unequal Double Branch (Swept)	160 x 110	BS 4514:1983
Unequal Double Branch W/I/O (Swept)	160 x 110	BS 4514:1983
Vent Cowl	50, 82, 110 & 160	MS 978:1985 / BS 4514:1983
WC Connecting Bend	110	BS 4514:1983
WC Connecting Bend W/I/O	110	BS 4514:1983
WC Pan Connector	110	BS 4514:1983
WC Pan Elbow Connector	110	BS 4514:1983

Tritech Pipe

Greater Performance & Durability

Tritech Pipe - a three-layer pipe system that provides **superior performance** at an affordable price.

It is constructed from premium quality materials and reliable technology that ensures long term performance. The three layers are made of **high quality materials** that are 100% virgin and time-tested to provide greater stability and durability.

Paling Tritech combines technologically advanced materials and sophisticated expertise to provide customers with excellent quality pipes that guarantee satisfaction and greater appreciation for a better living environment.

Greater Performance at an Affordable Price

Paling Tritech pipes utilizes advanced technology in its production. This increase efficiency and productivity, allowing it to be **more competitively priced** in the market.

With the Paling Tritech, you no longer have to pay exorbitant amount of hard-earned cash to own a dependable pipe system for your residence. Enjoy exceptional performance at an affordable price.

The Paling Tritech has been certified by **SIRIM** to **BS EN 1453**, which is the latest standard used to specify SWV pipes performance and exceeds the stringent testing requirements in its standards.

Product Structure

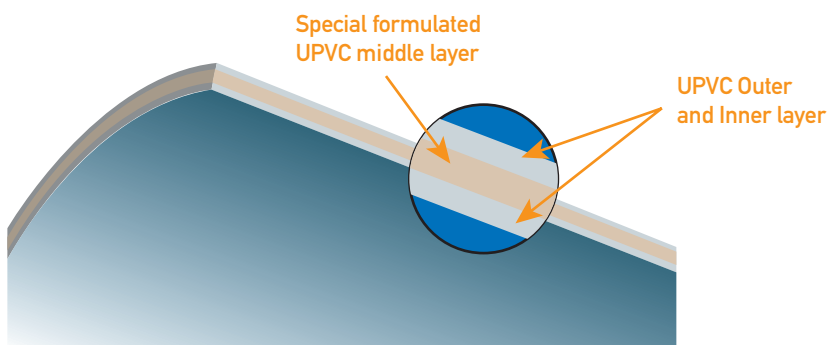

Size Available

Code No.	Nom. Size (mm)	Mean outside Diameter D (mm)		Min wall Thickness e (mm)	Length L (m)
		Min.	Max.		
1203 082 40	82	82.4	82.8	3.2 - 3.7	4
1203 110 40	110	110.0	110.3	3.2 - 3.8	4
1203 160 40	160	160.0	160.4	3.2 - 3.8	4
1203 082 60	82	82.4	82.8	3.2 - 3.7	6
1203 110 60	110	110.0	110.3	3.2 - 3.8	6
1203 160 60	160	160.0	160.4	3.2 - 3.8	6

Soil, Waste & Vent Pipes

For solvent weld connection to all fittings.

CODE NO.	NOM. SIZE (mm)	Mean Outside Diameter D (mm)		Min Wall Thickness e(mm)	Length L (m)
		min	max		
1200 032 40	32	36.15	36.45	1.8	4
1200 040 40	40	42.75	43.05	1.9	4
1200 050 40	50	55.75	56.05	2.0	4
1200 050 60	50	55.75	56.05	2.0	6
1200 082 40	82	82.4	82.8	3.2	4
1200 082 60	82	82.4	82.8	3.2	6
1200 110 40	110	110.0	110.4	3.2	4
1200 110 60	110	110.0	110.4	3.2	6
1200 160 40	160	160.0	160.6	3.2	4
1200 160 60	160	160.0	160.6	3.2	6

Other lengths are available on special order.

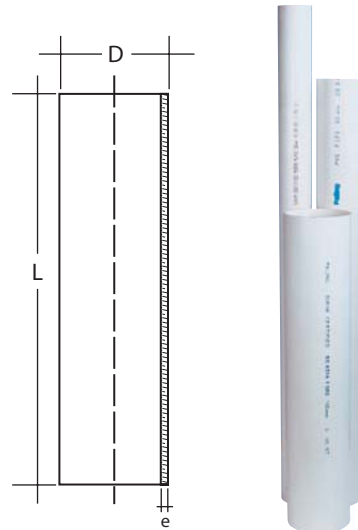

Bend (Swept)

To solvent weld to pipes or fittings at both ends.

CODE NO.	NOM. SIZE (mm)	ANGLE		DIMENSIONS (mm)		
		θ	L	A	B	D
2201 032	32	88 3/4°	24.0	28.0	30.0	36.6
2201 040	40	88 3/4°	28.0	27.0	28.0	43.2
2201 050	50	88 3/4°	30.0	32.0	32.0	56.2
2201 082	82	87 1/2°	43.0	80.0	76.0	83.1
* 2201 110	110	87 1/2°	51.0	75.0	71.0	110.6
* 2201 160	160	87 1/2°	76.0	129.0	129.0	160.8

* Available in MF & FF

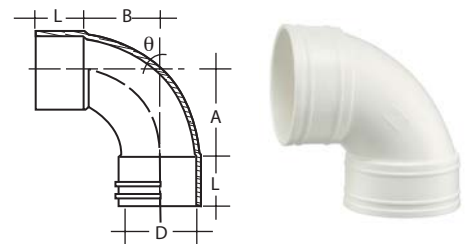

Bend (Swept) with Inspection Opening

To solvent weld to pipe, fitted with inspection opening.

CODE NO.	NOM. SIZE (mm)	ANGLE		DIMENSIONS (mm)		
		θ	L	A	B	D
2202 040	40	88 3/4°	28.0	27.0	28.0	43.2
2202 050	50	88 3/4°	30.0	32.0	32.0	56.2
2202 082	82	87 1/2°	43.0	80.0	76.0	83.1
* 2202 110	110	87 1/2°	51.0	75.0	71.0	110.6
* 2202 160	160	87 1/2°	76.0	129.0	129.0	160.8

* Available in MF & FF

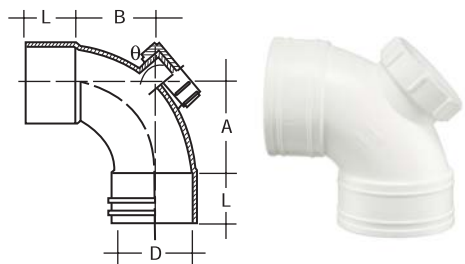

Knuckle Bend Plain

CODE NO.	NOM. SIZE (mm)	DIMENSIONS (mm)		
		L	D	A
2203 032	32	21.0	36.6	45.0
2203 040	40	24.0	43.2	52.0

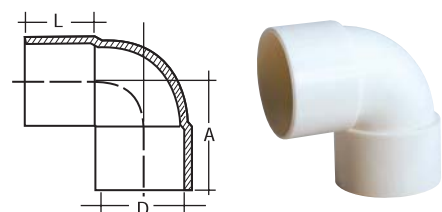

Bend (Unswept)

To solvent weld to pipe.

CODE NO.	NOM. SIZE (mm)	ANGLE		DIMENSIONS (mm)		
		θ	L	A	B	D
2210 032	32	45°	23.0	6.0	6.0	36.6
2210 040	40	45°	27.0	8.0	8.0	43.2
2210 050	50	45°	30.0	10.0	10.0	56.2
2210 082	82	45°	43.0	15.0	15.0	83.1
2210 110	110	45°	50.0	20.0	20.0	110.6
2210 160	160	45°	76.0	30.0	30.0	160.8

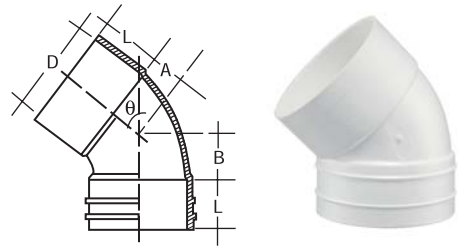

Bend (Unswept) with Inspection Opening

To solvent weld to pipe, fitted with inspection opening.

CODE NO.	NOM. SIZE (mm)	ANGLE		DIMENSIONS (mm)		
		θ	L	A	B	D
2203 050	50	45°	30.0	10.0	10.0	56.2
2203 082	82	45°	43.0	15.0	15.0	83.1
2203 110	110	45°	50.0	20.0	20.0	110.6
2203 160	160	45°	76.0	30.0	30.0	160.8

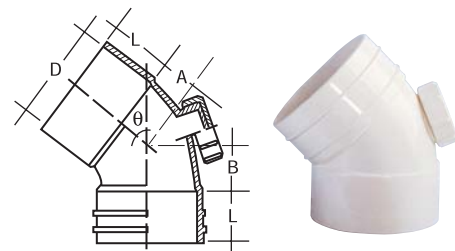

Branch (Swept)

To solvent weld to pipe.

With integrally moulded boss adaptor socket to accept waste pipes or fittings.

CODE NO.	NOM. SIZE (mm)	ANGLE		DIMENSIONS (mm)					
		θ	L	A	B	C	E	D	D1
2211 032	32	88 3/4°	23.3	30.0	93.0	-	-	36.6	36.6
2211 040	40	88 3/4°	27.0	35.0	109.0	-	-	43.2	43.2
2211 050	50	88 3/4°	30.0	50.0	136.0	-	-	56.2	56.2
2211 082	82	87 1/2°	45.0	76.0	206.0	-	43.0	83.1	83.1
* 2211 110	110	87 1/2°	50.0	75.0	250.0	-	56.0	110.6	110.6
2211 160	160	87 1/2°	77.0	155.0	360.0	83.0	56.0	160.8	160.8
+ 2211 160 110	160x110	87 1/2°	160.3	125.0	372.0	-	56.0	160.8	110.6

* Available in MF & FF
+ Reducing Branch



Branch (Swept) with Inspection Opening

To solvent weld to pipe.

With integrally moulded boss adaptor socket to accept waste pipes or fittings.

CODE NO.	NOM. SIZE (mm)	ANGLE		DIMENSIONS (mm)					
		θ	L	A	B	C	E	D	D1
2212 040	40	88 3/4°	27.0	35.0	109.0	-	-	43.2	43.2
2212 050	50	88 3/4°	30.0	50.0	136.0	-	-	56.2	56.2
2212 082	82	87 1/2°	45.0	76.0	206.0	-	43.0	83.1	83.1
* 2212 110	110	87 1/2°	50.0	75.0	250.0	-	56.0	110.6	110.6
2212 160	160	87 1/2°	77.0	155.0	360.0	83.0	56.0	160.8	160.8
+2212 160 110	160x110	87 1/2°	160.3	125.0	372.0	-	56.0	160.8	110.6

* Available in MF & FF
+ Reducing Branch



Branch (Unswept)

With integrally moulded boss adaptor socket to accept waste pipes or fittings.

CODE NO.	NOM. SIZE (mm)	ANGLE θ	DIMENSIONS (mm)				
			L	C	E	D	D1
2213 050	50	45°	30.0	-	-	56.2	56.2
2213 082	82	45°	44.0	-	43.0	83.1	83.1
2213 110	110	45°	51.0	83.0	56.0	110.6	110.6
* 2213 110 082	110x82	45°	45.0	83.0	56.0	110.6	83.1
2213 160 110	160x110	45°	50.0	83.0	56.0	160.8	110.6

* Combination item comprising Branch (2213 110) and Bush Socket Reducer (2236 110 082).

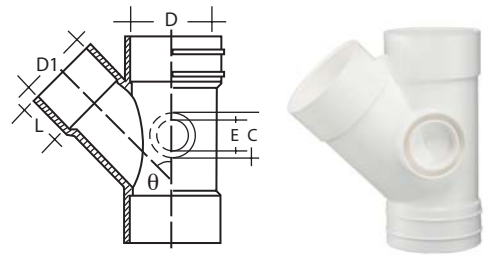

Branch (Unswept) with Inspection Opening

With integrally moulded boss adaptor socket to accept waste pipes or fittings.

CODE NO.	NOM. SIZE (mm)	ANGLE θ	DIMENSIONS (mm)				
			L	C	E	D	D1
2214 050	50	45°	30.0	-	-	56.2	56.2
2214 082	82	45°	44.0	-	43.0	83.1	83.1
2214 110	110	45°	51.0	83.0	56.0	110.6	110.6
2214 110 082	110x82	45°	45.0	83.0	56.0	110.6	83.1
2214 160 110	160x110	45°	50.0	83.0	56.0	160.8	110.6

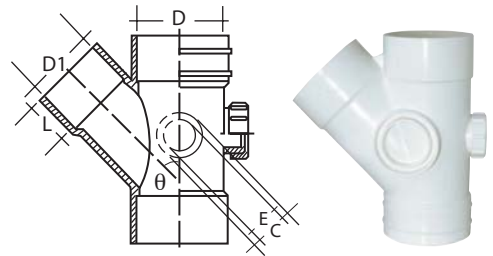

Equal Double Branch (Swept)

With integrally moulded boss adaptor socket to accept waste pipes or fittings.

CODE NO.	NOM. SIZE (mm)	ANGLE θ	L	DIMENSIONS (mm)			
				C	E	D	D1
2216 050	50	88 3/4°	28.5	-	43.0	56.2	56.2
2216 110	110	87 1/2°	50.5	82.5	56.0	110.6	110.6

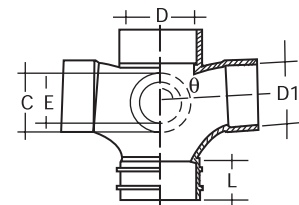

Equal Double Branch (Swept) with Inspection Opening

Access Plug (2229) connected to integrally moulded boss adaptor socket to provide inspection opening.

CODE NO.	NOM. SIZE (mm)	ANGLE θ	L	DIMENSIONS (mm)			
				C	E	D	D1
2217 050	50	88 3/4°	30.0	-	43.0	56.2	56.2
2217 110	110	88 1/2°	50.0	83.0	56.0	110.6	110.6
* 2217 160 110	160x110	88 1/2°	76.0	83.0	56.0	160.8	110.6

* Combination item comprising Reducing Double Branch (2219 160 110) and 41° Bend.

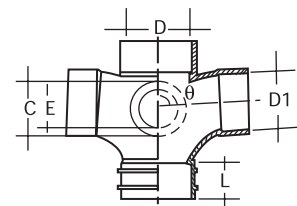

1,2,3 & 4 Way Branch (Unswept)

To allow for waste pipe connection above soil branch.

CODE NO.	NOM. SIZE (mm)	ANGLE		DIMENSIONS (mm)				
		θ	L	L1	D	D1	D2-D5	
(1) 2231	110x50	88°	150.0	35.0	110.6	110.2	56.0	
(2) 2232	110x50	88°	150.0	35.0	110.6	110.2	56.0	
(3) 2233	110x50	88°	150.0	35.0	110.6	110.2	56.0	
(4) 2234	110x50	88°	150.0	35.0	110.6	110.2	56.0	

- (1) One Way Branch (2) Two Way Branch
(3) Three Way Branch (4) Four Way Branch

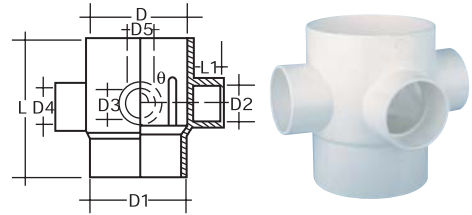

Reducing Double Branch (Unswept)

With integrally moulded boss adaptor socket to accept waste pipes or fittings.

CODE NO.	NOM. SIZE (mm)	ANGLE		DIMENSIONS (mm)						
		θ	L	L1	B	C	E	D	D1	
2218	160x110	45°	71.0	50.0	173.0	83.0	56.0	160.8	110.6	

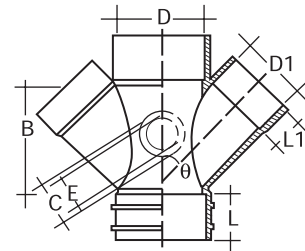

Reducing Double Branch (Unswept)

With integrally moulded boss adaptor socket to accept waste pipes or fittings.

CODE NO.	NOM. SIZE (mm)	ANGLE		DIMENSIONS (mm)						
		θ	L	L1	B	W	C	E	D	D1
2216	160x110	87½°	71.0	50.0	173.0	260.0	83.0	56.0	160.8	110.6

Combination of 2218 160 110 and 41° Bend

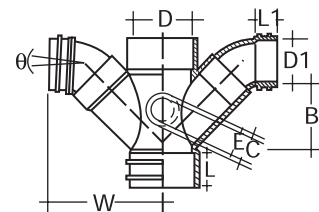

Reducing Double Branch (Unswept) with Inspection Opening

Access Plug (2229) connected to integrally moulded boss adaptor socket to provide inspection opening.

CODE NO.	NOM. SIZE (mm)	ANGLE		DIMENSIONS (mm)						
		θ	L	L1	B	C	E	D	D1	
2219	160x110	45°	71.0	50.0	173.0	83.0	56.0	160.8	110.6	

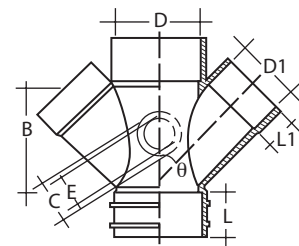

Straight Coupler

To solvent weld together two lengths of soil or waste pipes.

CODE NO.	NOM. SIZE (mm)	L	DIMENSIONS (mm)		
			A	B	D
2225 032	32	25.3	3.0	56.0	36.6
2225 040	40	28.0	3.0	59.0	43.2
2225 050	50	32.0	3.0	67.0	56.2
2225 082	82	42.0	3.0	96.0	83.1
2225 110	110	51.0	3.2	112.0	110.6
2225 160	160	77.0	4.3	161.0	160.8

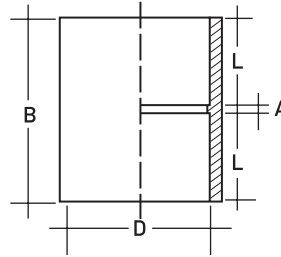

Pipe Sleeve

For cast into RC floor slab/concrete wall to provide a through socket for pipes.

CODE NO.	NOM. SIZE (mm)	H	DIMENSIONS (mm)	
			D	D1
2252 032	32	112.0	72.0	56.0
2252 040	40	112.0	79.0	67.5
2252 050	50	112.0	92.0	75.5
2252 082	82	112.0	120.0	104.0
2252 110	110	112.0	147.0	131.0
2252 160	160	163.0	199.0	184.0

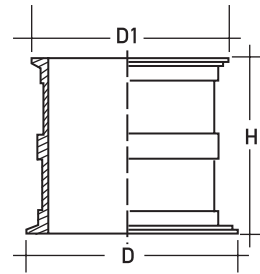

Expansion Coupler

To provide an expansion joint for pipe connection or other materials pipe connection at base of stack.
Combination of Seal Ring Adaptor (2242) & Straight Coupler (2225).

CODE NO.	NOM. SIZE (mm)	L	DIMENSIONS (mm)		
			L1	L2	D
2226 082	82	113.0	42.0	48.0	83.1
2226 110	110	133.0	51.0	55.0	110.6
2226 160	160	190.0	77.0	80.0	160.8

■ Rubber Ring Seal

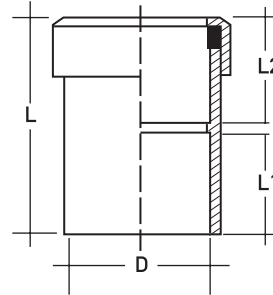

Socket Plug *with Screw on Cap*

To plug up the open-end of a pipe line, via a straight coupler, to allow for later accessibility.

CODE NO.	NOM. SIZE (mm)	DIMENSIONS (mm)			
		L	L1	D	D1
2229 032	32	45.0	23.0	36.3	32.0
2229 040	40	50.0	26.0	42.9	42.9
2229 050	50	46.0	28.0	55.9	52.5
2229 082 46	82	46.0	23.0	82.6	76.4
2229 082 67	82	68.0	44.0	82.6	76.4
* 2229 110 082	110	77.0	50.0	103.8	76.0

* Socket Plug dimension 'D' is internal diameter of 110 mm ø Pipe.

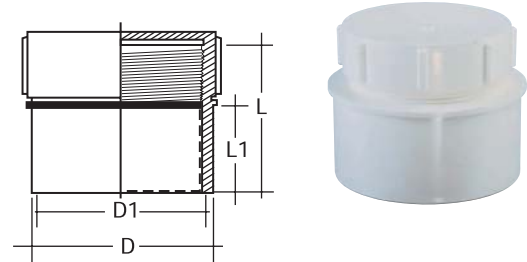

Bush/ Socket Reducer

To allow for change in fittings socket diameter.

CODE NO.	NOM. SIZE (mm)	DIMENSIONS (mm)			
		L	L1	D	D1
2236 040 032	40x32	22.0	17.0	42.9	36.6
2236 050 032	50x32	28.0	17.5	55.9	36.6
2236 050 040	50x40	28.0	21.0	55.9	43.2
2236 082 050	82x50	38.0	28.0	82.6	56.2
2236 110 050	110x50	50.0	27.0	110.2	56.2
2236 110 082	110x82	50.0	37.0	110.2	83.1
2236 160 110	160x110	71.0	48.5	160.3	110.6

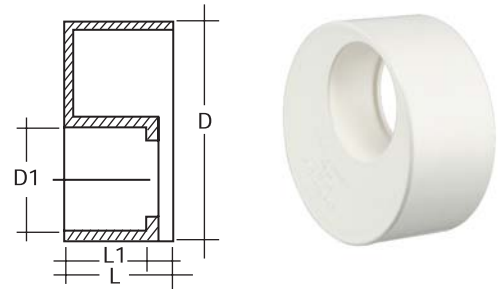

Level Invert Reducer

To allow for change in pipe diameter with larger end spigot to fitting and other end socket to pipe.

CODE NO.	NOM. SIZE (mm)	DIMENSIONS (mm)				
		L	L1	A	D	D1
2239 050 032	50x32	32.0	23.5	19.0	36.6	55.9
2239 082 050	82x50	45.0	27.0	35.0	56.2	82.6
2239 110 050 145	110x50	51.0	36.0	68.0	56.2	110.2
2239 110 082	110x82	50.0	43.0	35.0	83.1	110.2

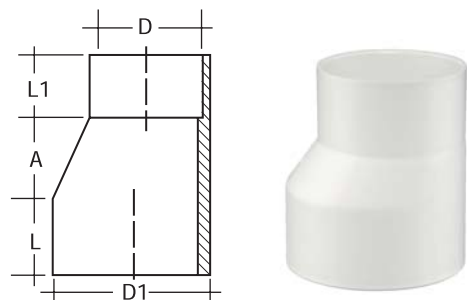

Concentric Reducer

To allow for change in pipe diameter mainly used with 'P' Trap (2246 & 2247), Grating (2254), and Extension Grating Collar (2255).

CODE NO.	NOM. SIZE (mm)	DIMENSIONS (mm)				
		L	L1	L2	D	D1
* 2239 082 050 83	82x50	83.0	32.0	25.0	75.6	56.2
+ 2239 110 050	110x50	109.0	50.0	28.0	110.4	56.2
2239 160 110	160x110	148.0	75.0	49.0	160.3	110.6

* Concentric Reducer dimension 'D' is the internal diameter of 82 mm pipe.
+Concentric Reducer dimension 'D' is the outer diameter of 110 mm pipe.

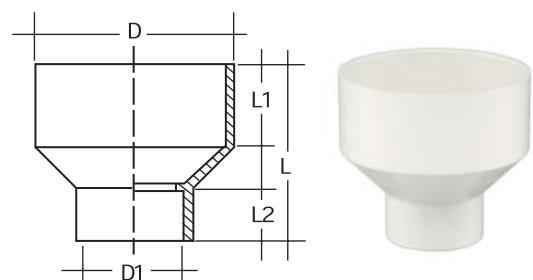

Inspection Opening & Frame

Solvent weld to pipe for access to stack.

CODE NO.	NOM. SIZE (mm)	L	DIMENSIONS (mm)		
			A	B	
2238 082 050	82x50	92.0	56.5	47.0	
2238 110 050	110x50	122.0	56.5	47.0	
2238 110 082	110x82	122.0	82.2	71.0	
2238 160 082	160x82	175.0	82.2	71.0	

Combination of Boss Connector (2243) & Socket Plug with screw on cap (2229).

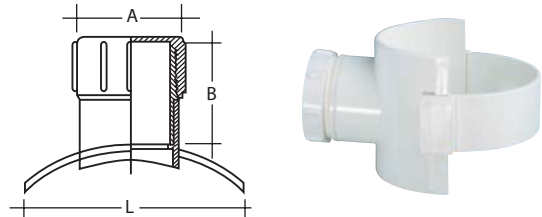

WC Connecting Bend

For WC Pans to BS 5503

CODE NO.	NOM. SIZE (mm)	ANGLE θ	DIMENSIONS (mm)		
			L	L1	D
2208 110	110	90°	50.0	25.0	110.6
* 2209 110	110	90°	50.0	25.0	110.6

* With Inspection Opening.

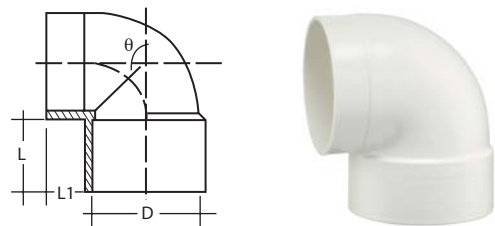

WC Pan Connector

For WC Pans to BS 5503.

CODE NO.	NOM. SIZE (mm)	DIMENSIONS (mm)				
		L	A	B	C	D
2240 110	110	36.0	98.0	64.0	121.0	103.0

■ Rubber Ring Seal

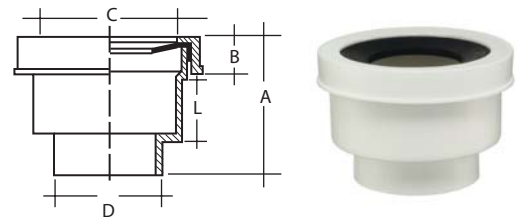

WC Pan Elbow Connector

For WC Pans to BS 5503.

CODE NO.	NOM. SIZE (mm)	L	DIMENSIONS (mm)		
			A	B	D
2241 110	110	50.0	54.0	55.0	110.6

■ Rubber Ring Seal

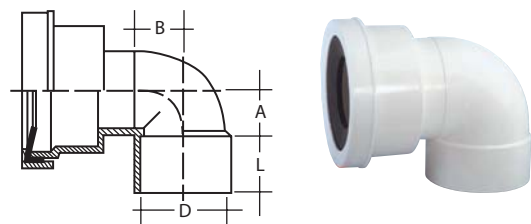

Seal Ring Adaptor

To solvent weld to fittings for conversion to ring seal expansion joint.

CODE NO.	NOM. SIZE (mm)	L	DIMENSIONS (mm)	
			A	D
2242 082	82	31.0	5.0	82.6
2242 110	110	38.0	7.0	110.2
2242 160	160	42.0	9.0	160.4

■ Rubber Ring Seal

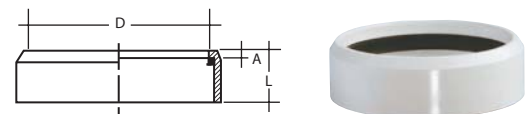

Boss Connector with Bracket

To connect waste pipe to soil and for venting by solvent cement.
Incorporates a bracket specially designed to hold boss connector in place during installation.

CODE NO.	NOM. SIZE (mm)	DIMENSIONS (mm)		
		D	A	Dr
* 2243 082 032	82x32	36.6	19.0	82.0
• 2243 082 040	82x40	43.2	22.0	82.0
2243 082 050	82x50	56.2	30.0	82.0
+2243 110 032	110x32	36.6	19.0	110.0
° 2243 110 040	110x40	43.2	22.0	110.0
2243 110 050	110x50	56.2	30.0	110.0
2243 110 082	110x82	83.1	45.0	110.0
2243 160 082	160x82	83.1	45.0	160.0

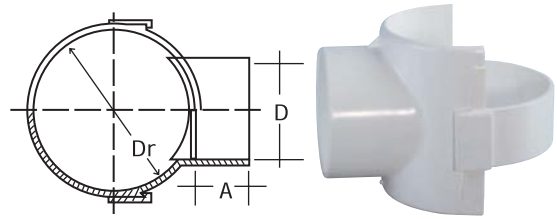

Dr-Nominal diameter of pipe
D - Diameter of inlet pipe
A - Socket depth

- * Combination of Boss Connector (2243 082 050) & Bush Socket Reducer (2236 050 032)
- Combination of Boss Connector (2243 082 050) & Bush Socket Reducer (2236 050 040)
- + Combination of Boss Connector (2243 110 050) & Bush Socket Reducer (2236 050 032)
- ° Combination of Boss Connector (2243 110 050) & Bush Socket Reducer (2236 050 040)

'P' Trap

'P' Trap with water seal for gas-tight connection to SWV system

CODE NO.	NOM. SIZE (mm)	DIMENSIONS (mm)						
		L	L1	A	C	D	D1	
2246 050	50	28.0	28.0	210.0	125.0	56.2	-	
* 2246 082	82	45.0	45.0	290.0	140.0	83.1	-	
2246 110	110	50.0	50.0	310.0	160.0	110.6	55.9	

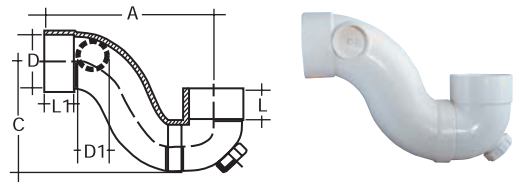

* Fabricated item

'P' Trap with Vent

'P' Trap with water seal for gas-tight connection to SWV system.
Bossed socket to allow for connection to vent pipe.

CODE NO.	NOM. SIZE (mm)	DIMENSIONS (mm)							
		L	L1	A	C	D	D1	D2	
2247 050 032	50x32	28.0	28.0	210.0	125.0	56.2	36.3	-	
2247 110 050	110x50	50.0	50.0	310.0	160.0	110.6	55.9	55.9	

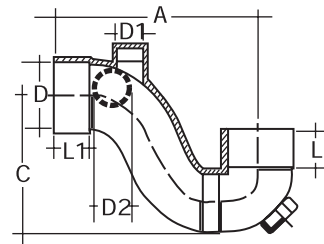

'S' Trap

With water seal for gas-tight connection to SWV System.

CODE NO.	NOM. SIZE (mm)	DIMENSIONS (mm)			
		L	H	C/C	D
2248 110	110	500.0	270.0	390.0	110.6

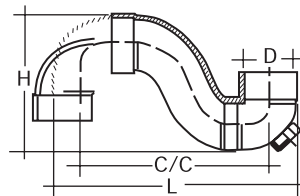

Vent Cowl

To cap open end of soil and vent stack, solvent welded to pipe.

CODE NO.	NOM. SIZE (mm)	DIMENSIONS (mm)	
		L	A
2250 050	50	28.5	75.0
2250 082	82	24.0	70.0
2250 110	110	25.0	90.0
2250 160	160	47.0	143.0

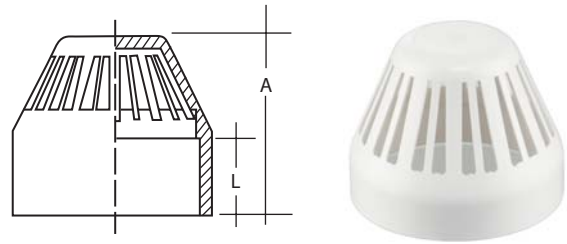

Weather Apron Flat

CODE NO.	NOM. SIZE (mm)	DIMENSIONS (mm)		
		A	B	C
2253 110 075	110	76.0	45.0	110.4

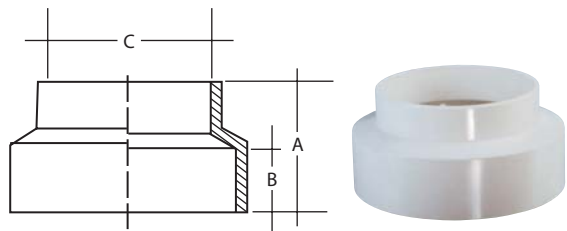

Weather Apron 22°

CODE NO.	NOM. SIZE (mm)	DIMENSIONS (mm)		
		A	B	C
2253 110 115	110	115.0	27.0	110.3

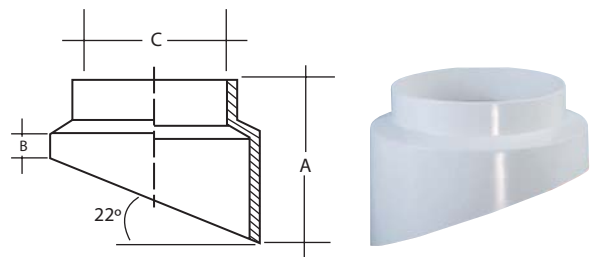

Grating

Can be seated into 82mm or 110mm drainage pipes or floor wells.

CODE NO.	NOM. SIZE (mm)	DIMENSIONS (mm)	
		L	C
2254 110 082	110x82	73.0	110.2

- A - 82mm** Seats on 82mm short length pipe solvent welded to Concentric Reducer (2239 082 050 83) and connected to 50mm P-trap (2246 or 2247).
- B - 110mm** Seats on 110mm short length pipe solvent welded to Floor Gully (2259 110).

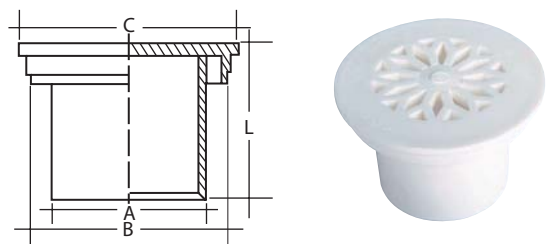

Extension Grating Collar

To be used as a collar for grating (2254 110 082)

CODE NO.	NOM. SIZE (mm)	DIMENSIONS (mm)				
		L	A	A1	B	B1
2255 110 014	110x14	118.0	110.5	110.0	33.0	14.0
2255 110 020	110x20	118.0	110.5	110.0	33.0	20.0

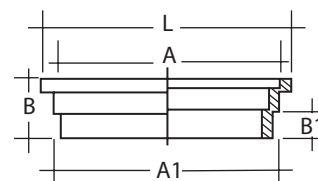

Floor Gully S-191

CODE NO.	NOM. SIZE (mm)	DIMENSIONS (mm)			
		L	L1	L2	D
2258 110 S191	110	84	105	127	50

Imported fitting from Aliaxis

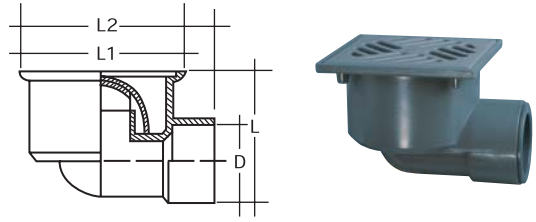

Floor Gully S-228

CODE NO.	NOM. SIZE (mm)	DIMENSIONS (mm)				
		L	L1	L2	L3	D
2258 110 S228	110	105	145	170	116	ø50/ø40

Imported fitting from Aliaxis

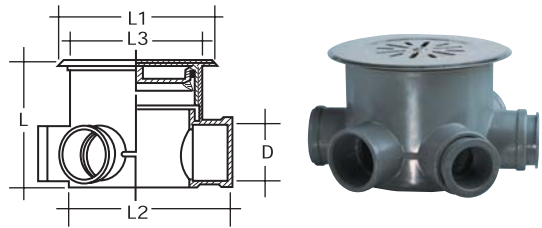

Floor Gully with Trap

Floor Gully comes complete with water trap, extension grating collar (2255) and grating (2254) together with snap-in-cover, outlet may be rodded by removing grating.

CODE NO.	NOM. SIZE (mm)	DIMENSIONS (mm)					
		L	L1	A	B	D	D1
2258 110 085	110(85)x40	85.0	90.0	32.0	118.0	43.0	38.6
2258 110 105	110(105)x40	105.0	70.0	32.0	118.0	43.0	38.6

PP grating & collar

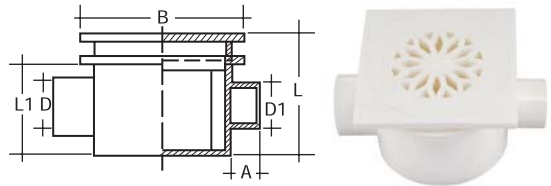

Floor Gully with Trap & Inspection Opening

Integrally moulded boss adaptor with 40mm (D3) & 50mm (D2) socket to accept waste pipe or other fittings.

CODE NO.	NOM. SIZE (mm)	DIMENSIONS (mm)				
		L	D	D1	D2	D3-D4
2259 110	110	190	110.4	83.1	56.0	42.9
* 2259 110 050	110x50	190	110.4	56.2	56.0	42.9

■ Rubber Ring Seal

* Combination of 2259 110 & 2236 080 050

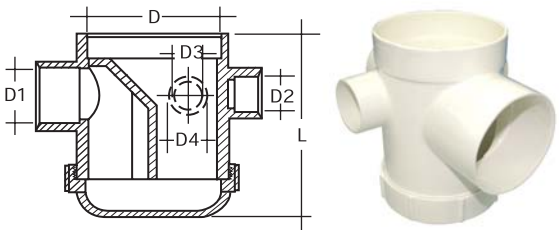

Bottle Trap

CODE NO.	NOM. SIZE (mm)	DIMENSIONS (mm)		
		H	W	D
2260 032	32	151.0	66.5	36.3
2260 040	40	174.0	74.4	42.9

With plug & chain

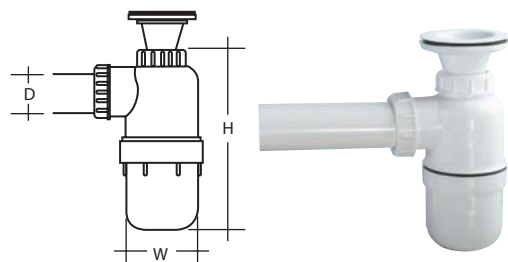

Top Removable Trapped Floor Gully

Material : MuPVC

Under-floor trap to receive up to 3 waste pipe connections
Sockets to accept 50 mm waste pipe
Outlet socket sizes at 2 - 1/2 fall: - 82 mm

Seal depth : 50 mm meets BS EN 1253-1

Cleaning access via removable baffle with integral gasket to maintain airtight seal.
Upper socket can accept standard 110 soil pipe.

Size : 110/82

Colour : White

Blanked off base of socket may be drilled out to make waste connection
(recommended hole saw size 38 mm)

29 mm depth, pipe size socket (solvent weld joint)
to take raising piece, or pipe if required

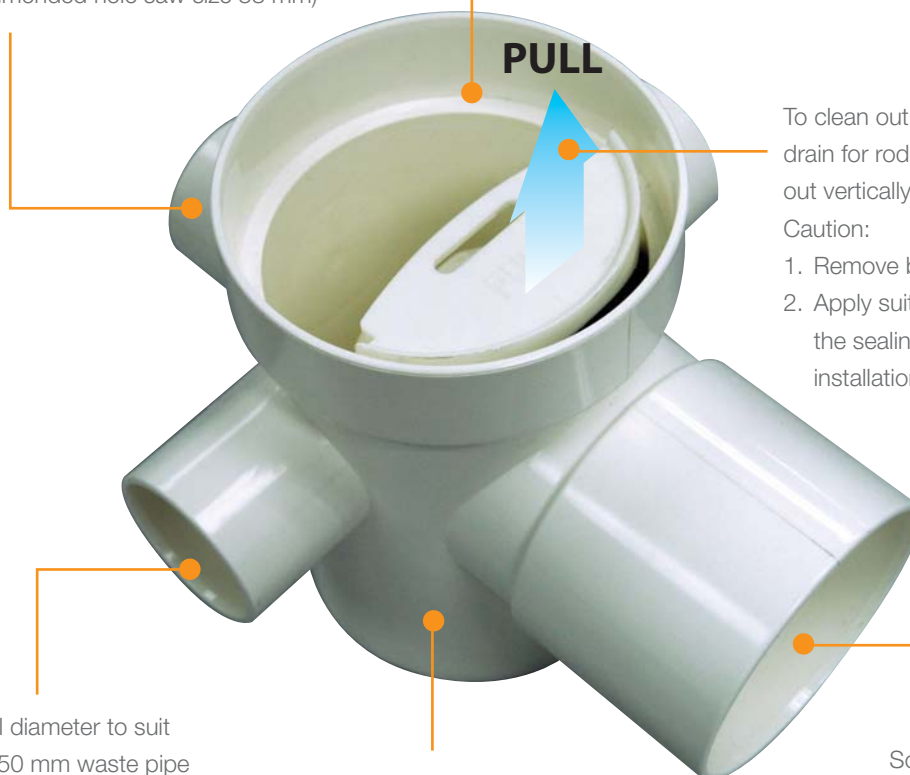

To clean out bowl, and to gain access to drain for rodding remove baffle by pulling out vertically

Caution:

1. Remove baffle before drilling out socket.
2. Apply suitable lubricant on the seal and the sealing wall of gully body for easy installation of baffle.

Internal diameter to suit
Paling 50 mm waste pipe
direct (Solvent Weld Joint).

50 mm deep water seal
complies with BS EN 1253-1

Solvent Weld outlet to take
Paling soil pipe or waste pipe
with appropriate adaptor

Advantages:

1. Removable trap, easier and simple way to clean
2. No rubber ring seal, no leakage.
3. Easier solution for adding for collar for higher false ceiling.
4. Save cost, can receive up to 3 waste pipe connection without additional fittings.
5. Prevent insect, cockroaches and gases entering building.

Dimension

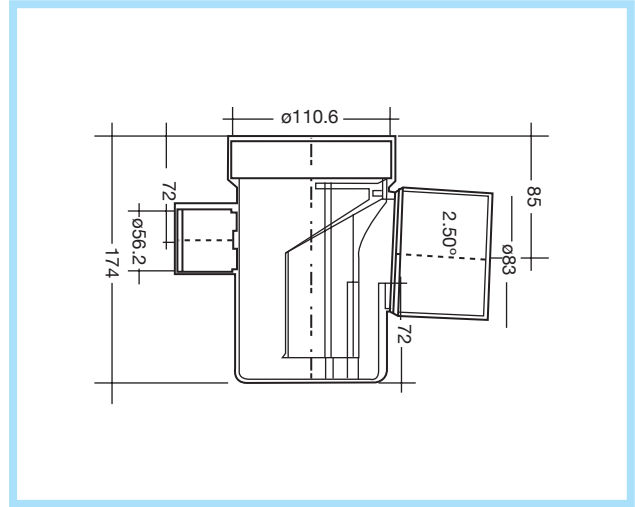
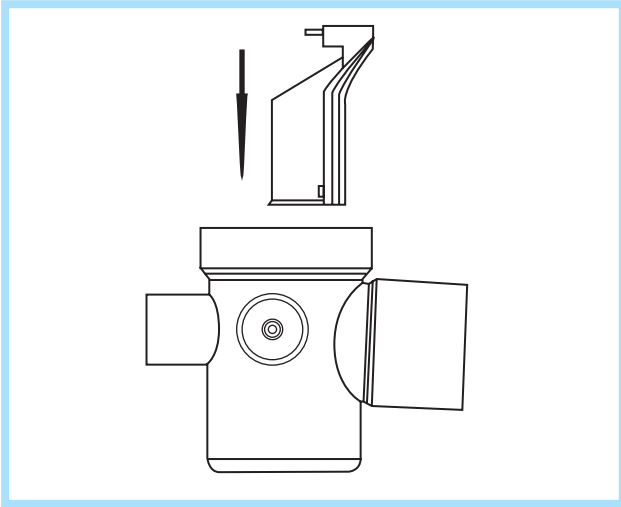

Method of Installation

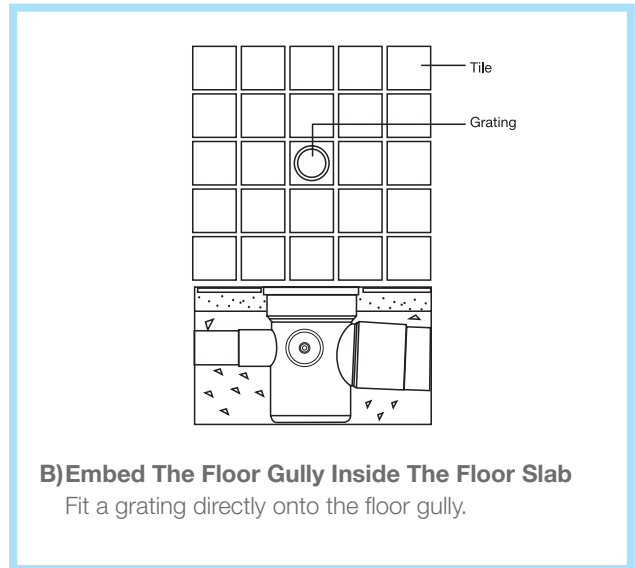
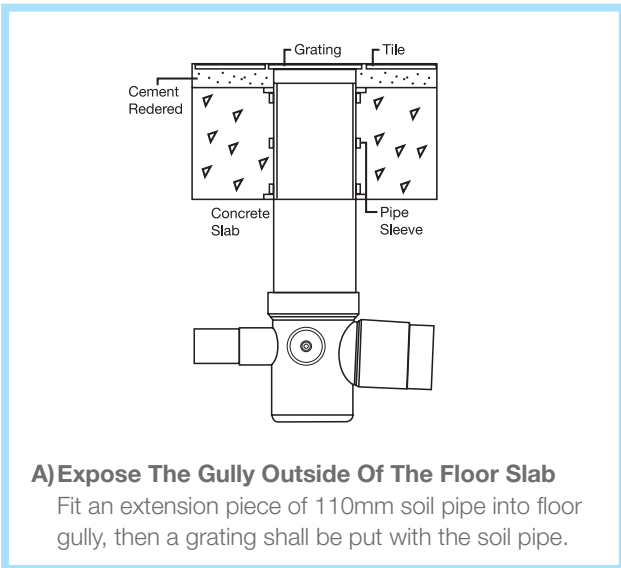

Step 1

Check overall height of unit with inlet in position, and adjust to suit installation location. (Do NOT solvent weld inlet at this stage)

Step 2

Place gully into position

Step 3

Solvent-weld waste pipe to outlet socket

Step 4

Bring floor screed up to level with bottom of gully inlet

Step 5

Allow screed to set, and remove gully inlet

Step 6

Apply waterproof mastic to underside of square flange of gully inlet

Step 7

Solvent cement gully inlet into position

Step 8

Tile up to inlet, and grout using waterproof grout

Typical Soil, Waste & Vent Piping layout for a 2 storey house using

PALING SWV Pipes & Fittings

- A** 110 mm
Vent Cowl
- B** 110 mm
Weather Apron
- C** 82 mm
uPVC Rainwater
Down Pipe
- D** 32 mm
Bend (Swept)
- E** 32 mm
uPVC Pipe
- F** 32 mm
Bottle Trap
- G** 40 x 32 mm
Bush Socket
Reducer
- H** 50 mm
'P' Trap
- I** 110 x 82 mm
Grating with
Extension Collar
- J** 110 x 82 mm
Floor Gully with Trap & I/O
- K** 82 mm
uPVC Pipe
- L** 82 mm
Bend (Swept)
- M** 110 mm
Bend W/I/O (Swept)
- N** 110 x 82 mm
Level Invert Reducer
- O** 110 mm
Single Branch (Swept)
- P** 110 mm
Underground
Bend (Swept)
- Q** 110x40 mm
Boss Connector
- R** 110 mm
WC Pan Connector
- S** 40 mm
Bottle Trap
- T** 110 mm
uPVC Soil Stack
- U** 82x50 mm
Concentric Reducer
- V** 110 mm
Expansion Coupler
- W** 82 mm
uPVC Pipe
- X** 110 mm
Underground uPVC
Pipe
- Y** 110 mm
Underground 'P' Trap

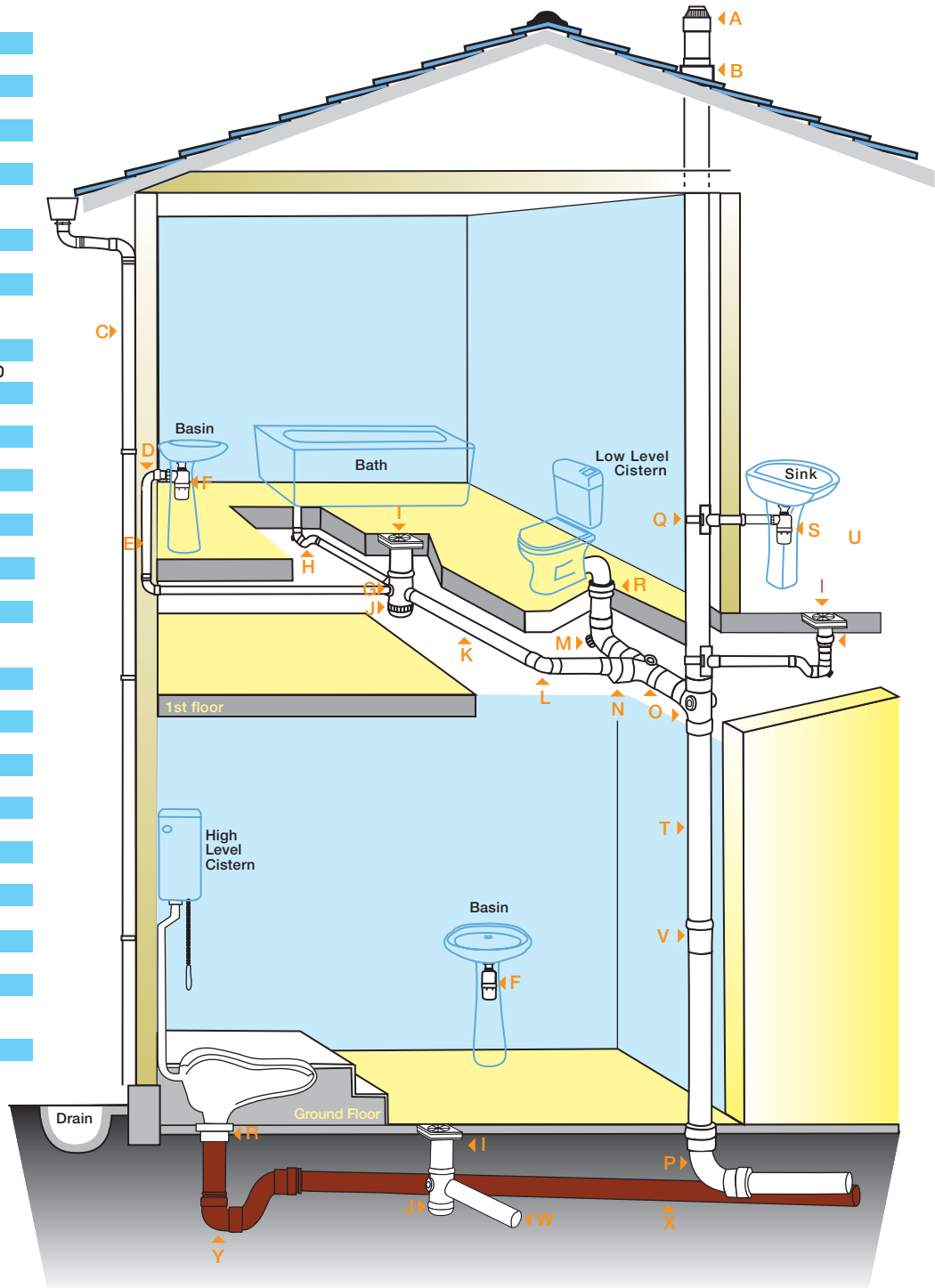

Typical Soil, Waste & Vent Piping Layout for a 3 storey flat using

PALING SWV Pipes & Fittings

- A** 110 mm Vent Cowl
- B** 110 mm Weather Apron
- C** 110 x 50 mm Boss Connector
- D** 32 mm Bottle Trap
- E** 32 mm uPVC Pipe
- F** 110 x 82 mm Grating with Extension Collar
- G** 40 mm Bottle Trap
- H** 40 mm uPVC Pipe
- I** 50 mm 'P' Trap
- J** 110 x 82 mm Floor Gully with Trap & Inspection Opening
- K** 110 mm Branch (Swept)
- L** 110 mm uPVC Soil Stack
- M** 50 mm uPVC Vent Stack
- N** 110 mm 'P' Trap with Vent
- O** 110 mm Expansion Coupler
- P** 82 mm uPVC Pipe
- Q** 110 mm WC Pan Connector
- R** 110 mm Underground uPVC Pipe

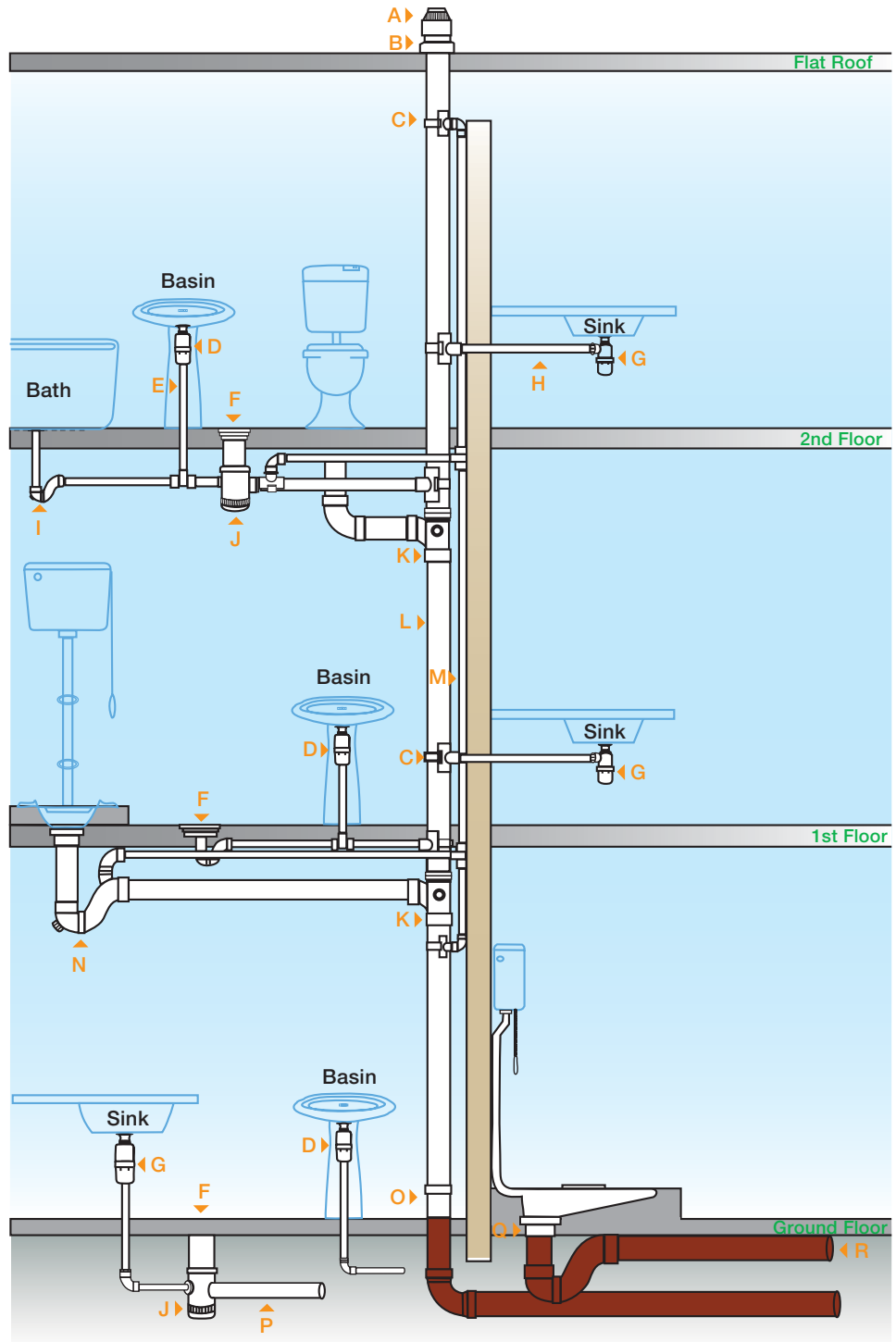

Joining

A - uPVC To Vitrified Clay Joints

Joints between pipes and vitrified clay sockets shall be made by applying solvent cement evenly to the pipe end for the full engagement length, and while wet, coat the surface with clean sharp sand, the joint shall then be finished by filling the annular jointing space with cement mortar, or by approved epoxy jointing compound. Both materials shall be neatly splayed off.

B - uPVC To G. I. Joints

Joints between pipes and steel tubes shall be made by means of a threaded adaptor. Polytetrafluorethylene (PTFE) tape shall be used on the thread as sealant, and hemp shall not be used.

C - uPVC To Copper Or Brass Tube Joints

Joints between pipes and copper or brass tubes, shall be made by means of a threaded adaptor solvent cemented to the pipe and screwed into an approved brass adaptor, silver brazed to the copper or brass tube.

D - uPVC To Cast Iron Joints

Joints between pipes and cast iron sockets shall be made as follows:

- 1- For caulked joint sockets by filling the annular jointing space with an approved epoxy jointing compound, neatly splayed off.
- 2- For bottled gland joint by means of a gasket gland ring.

Co-efficient of Thermal Expansion

uPVC has a coefficient of linear expansion of $7 \times 10^{-5} / ^\circ\text{C}$. This means that 1 metre length of pipes will expand approximately 0.70 mm per 10°C rise in temperature of the pipe material. However due to the short duration of most effluent flows and the slow temperature response of the material, the greatest thermal movements take place due to variation in environmental temperature rather than the effect of hot effluent discharge. Successful accommodation of thermal movement is dependent on the control direction and distribution of this movement.

The following notes are based on general practice but because of minor variations in By-law and Codes of Practice reference should be made to the appropriate statutory authority.

General

In assembling pipes and fittings particular care shall be taken to establish proper gradient and alignment before jointing. Grading and aligning pipes and fittings by straining shall not be allowed.

Storage

Pipes stacked for transport or long term storage should be continuously and evenly supported to minimise distortion. Alternatively supports of at least 75mm bearing widths, at spacing not greater than 1.5 metres centres, should be placed beneath the pipes. In such load bearing packs, maximum free height should be

Disclaimer

This brochure has been compiled by Paling Industries Sdn Bhd ("the company") to promote better understanding of the technical aspects of the Company's products to assist users in obtaining from them the best possible performance. The brochure is supplied subject to acknowledgment of the following conditions:

i) The brochure is protected by Copyright and may not be copied or reproduced in any form or by any means in whole or in part without prior consent in writing by the Company. ii) Product specifications, usage data and advisory information may change from time to time with advances in research and field experience. The Company reserves the right to make such changes at any time without notice. iii) Correct usage of the Company's products involve engineering judgements which cannot be properly made without full knowledge of all the conditions pertaining to each specific installation. The Company expressly disclaims all and any liability to any person done by any such person in reliance whether whole or partial upon the whole or any part of the contents of this brochure. iv) No offer to trade, nor any conditions of trading, are expressed or implied by the issue or content of this brochure. v) Nothing herein shall override the Company's conditions of Sale, which may be obtained from the Registered Office or any Sales Office of the Company. vi) This brochure is and shall remain the property of the Company, and shall be surrendered on demand to the Company.



The Water Delivery System

PALING INDUSTRIES SDN BHD (11039 V)

Lot 12, Jalan Perusahaan 4, 68100 Batu Caves, Selangor Darul Ehsan, Malaysia.

Tel: 603 - 6189 8333 (General) / 603 - 6189 6389 (Sales)

Fax: +603 6188 3810

Email: sales@paling.com.my

Website: www.paling.com.my

Distributed by: